

estelon

**Y-Series: Model YB**  
**Limited Edition CHAMPAGNE GOLD**  
**USER'S MANUAL**

**Your ESTELON loudspeakers have passed our quality control:**

- Technical test passed.

***Andrus Aaslaid***

*Engineer,*

*Alfred & Partners*

- Listening test passed.

***Alfred Vassilkov***

*Head of Research and Development,*

*Alfred & Partners*

SERIAL NUMBER: .....

*Only 50 pairs of the Limited Edition "Champagne Gold" Model YB  
are available worldwide!*



*Alfred Vassilkov is the creator and designer of world's finest loudspeakers.*

Alfred has more than 30 years of experience in designing and engineering loudspeakers. It is a lifetime of experience, profound knowledge of science, fanatical attention to detail and a fine sense of design that he has united into one beautiful handmade line of products –  
**Estelon Y Series.**

## TECHNICAL SPECIFICATIONS

<b>Woofer:</b>	8"
<b>Mid Woofer:</b>	5,25"
<b>Tweeter:</b>	1" Beryllium
<b>Internal Wiring:</b>	Kubala-Sosna
<b>Frequency Response:</b>	30 - 40 000 Hz
<b>Power Rating:</b>	150 W
<b>Amplifier Power:</b>	Minimum 30 W
<b>Nominal Impedance:</b>	6 Ohms
<b>Sensitivity:</b>	86 dB/2.83 V
<b>Height:</b>	1285mm
<b>Width:</b>	365mm
<b>Depth:</b>	430mm
<b>Net Weight Total:</b>	40 kg per loudspeaker
<b>Shipping dimensions:</b>	1380x770x650mm (1 crate)
<b>Shipping Weight:</b>	116kg (with package)

Suggested room size 20-50 m<sup>2</sup>.

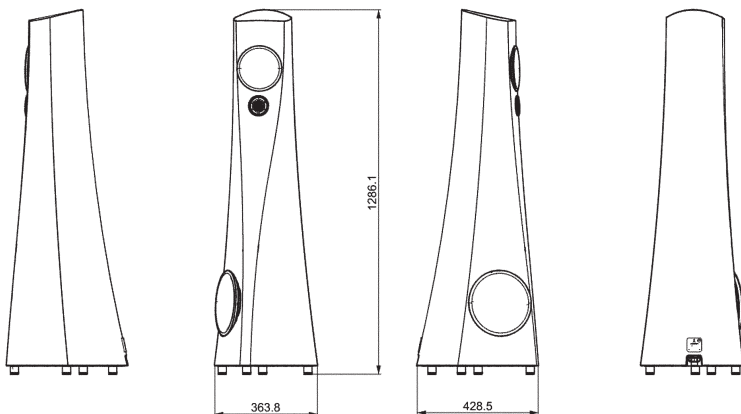

## UNPACKING INSTRUCTIONS

Your Estelon Model YB loudspeakers come packaged each in a carton box. For shipping, both boxes are packed in a plywood crate – we strongly recommend keeping the original package for possible future use / transport. The crate is collapsible for easier storage.

Bring the crate for unpacking as close as possible to the speakers positioning point\*. Due to the substantial weight and slippery surface of the loudspeakers we suggest that two (2) people assist in the unpacking and positioning of them for listening.

### Contents of the crate:

- Pair of loudspeakers / 2 boxes:
  - Left unit / 1 box
  - Right unit / 1 box
  - 2 Pairs of gloves and 1 Polishing Cloth

### Each Loudspeaker box contains:

- 4 feet (in the bottom of the loudspeakers)
- 3 grills
  - 1 Woofer grille
  - 1 Mid-Woofer grille
  - 1 Tweeter grille
- 1 Cloth bag to protect speaker finish
- 1 User Manual

*\* Recommended positioning point:*

*The positioning of the speakers in the room must be symmetrical for achieving a balanced sound stage – this is very important in a narrow room. Expect the distance between the speakers to be approximately 2 – 5 m, depending on the size of the room and its reverberation characteristics.*

*A “smooth” back wall will minimize imaging distortions. The distance between the back wall and the speaker should not be less than 0.5 m, the distance from the tweeter to the back and side walls must not be too similar.*

*When positioning the speakers in your room, if possible, it is desirable to allow for "free" space around the speakers so as to assist in minimizing sound reflections from walls, furniture etc. This will help in achieving correct tonality, realistic imaging, focus and dynamics. The recommended minimum distance between the speaker and the nearest reflection point is 1.0 m.*

*The best listening point: distance between your ears and the floor approx. 1 m (4,2 ft), the distance between the listener and the speakers should be similar to the distance between the two speakers.*

*The recommended speaker's direction is approximately 5°-7°, off axis, towards the listening position.*

**For unpacking**, please follow the instructions described below and as shown in the drawings.

NB! Please wear gloves supplied in the crate when cloth bags removed from the speakers.

1. Remove screws to open all locks on the bottom of the crate. This should only be done with the crate in a horizontal position.
2. Carefully lift the cover off the crate and put it aside. Please put on the gloves that you find included in the crate.
3. Carefully, one person lifting one of the carton boxes, and another person supporting, elevate the box with the speaker to a vertical position. Keep in mind the Speaker Top signs. Do not place the speaker on the top.
4. Remove the belts and then remove the carton.
5. Now carry the speaker to its position in the room. Please make sure the right speaker is placed on the right side and the left speaker on the left side as shown in drawing.
6. Remove the cloth bag.
7. Place the grilles on the drivers to protect from dust and damage.

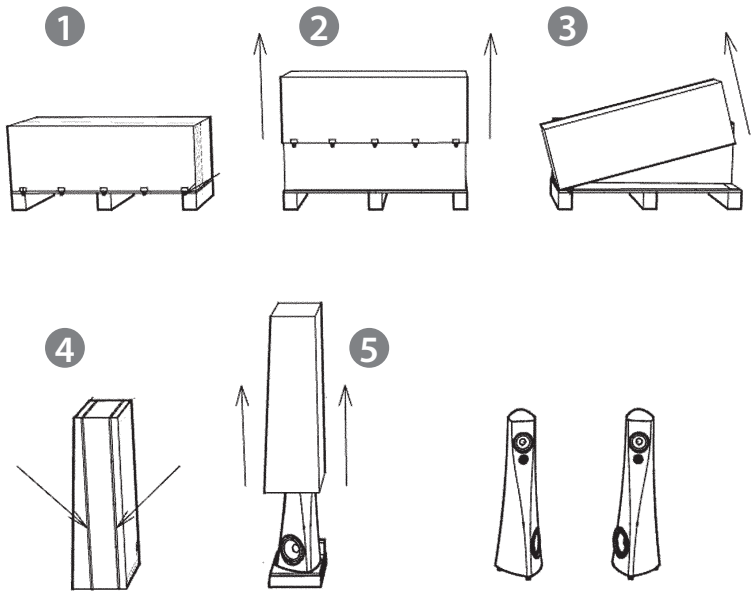

**Packing the speakers:** For packing follow the same procedures in the opposite direction.

## SETTING UP THE SYSTEM

### Now continue with wiring:

When connecting the speaker to the amplifier please make sure that the amplifier is in an off position.

Connect the speaker cable to the pole terminal on the back of the speaker: speaker terminal „+“ with the amplifier terminal „+“ and „-“ with „-“.

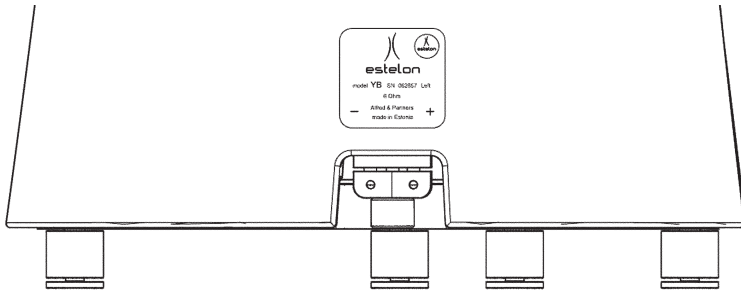

For better result we recommend connecting cables with spades. Loosen the knob, insert the both spades, then tighten the knob.

Please note that if you would like to use cables with the banana plug, loosen the knob first, insert the cables and then tighten the knob a little bit.

For signal flow, please follow the direction marked on the cable or in the cable manufacturer's instruction. Typically, the signal flow will be in the same direction as the labeling / writing on the cable.

### Break-in period:

Although your Estelon speakers had an initial break-in at the factory, due to shipping conditions - pressure/temperature changes that they may have incurred, the speakers will need to go through an additional break-in process before their final set-up and tuning.

All the mechanical and electrical connections will stabilize naturally after playing a continuous music signal for approx. 24 hrs – e.g. use a digital source in the repeat mode. After the initial break-in period you can start final tuning.



Please note that the speakers will have reached their optimum level of performance after playing in your system for 200-300 hrs.

### **Recommendations from Alfred Vassilkov for the set-up**

The set-up of the sound consists of the balancing of many different parameters: tonality, bass accuracy, focus, stage imaging, deepness etc. This process is time consuming and depends on the listener's experience or the qualification of the set-up specialist. Proper set-up will maximize your Estelons' performance.

During the final set-up small changes may be made to the initial chosen position, e.g. moving the speakers 10 cm towards the front wall, then maybe a little bit inward and outward. Please evaluate the sound carefully every time you make a small change in the positioning. Then continue, making smaller changes in the positioning and evaluate again, until the proper position with a balanced, natural sound is found. We suggest that you test, listen, with different music styles so as to avoid specific accents.

When changing the position of your speakers please keep in mind that:

- Close proximity to the back wall and corners will reinforce, enhance, the bass performance.
- A shorter distance between the two speakers, will create a better focus and deeper imaging, but will at the same time reduce the sound width.
- Pointing the speakers inward minimizes reflections from the side walls but has an impact on the imaging.

For critical listening, please allow 60-90 minutes for the system to stabilize, each time you play the speakers.

When played at excessive volume, you stand the risk of doing damage to the drivers.

*If you have any questions, please contact authorized Estelon dealer for assistance.*

## TAKING CARE OF YOUR ESTELON SPEAKERS

The multicoated finishes applied to Estelon speakers are considered to be amongst the most advanced automotive finishes available. They are extremely strong and durable. In order to assist you in maintaining their stunning appearance, your Estelon loudspeakers come supplied, from the factory, with special cleaning / polishing cloths. Please take note – *only dry cleaning is allowed* – do not wash the speakers.

When the nature of a smudge / spot so necessitates, a soft moist cloth may be used to gently liquefy / remove smudges prior to a final finishing with the special cloths which accompany the speakers. The use of other materials can damage, scratch or destroy the finish.

More detailed information regarding the polishing clothes and information for obtaining additional product:

### **For the Liquid Gloss finish only:**

DuPont™ Sontara® Polish Cloth impregnated with Krytox®  
Silicone-free

Impregnated with DuPont™ Krytox®, a high performance polish that gives a long-lasting shine and extra protection to paintwork  
No additional wax or polish required.

### **For all finishes:**

3M Perfect-it™ III High Performance Polishing Cloth  
Item # 50486  
Or other 3M Microfiber cloths

*For additional information and guidance regarding cleaning / polishing materials, please contact your dealer or distributor.*

## IMPORTANT INFORMATION

### Beryllium tweeter

Model YB includes a Beryllium tweeter. The outstanding sound and high performance it provides is made possible by utilizing a beryllium dome diaphragm, the diaphragm contains 99% pure beryllium. Beryllium in its pure form is a toxic substance, not to enter the human body and waste material must be controlled. It is therefore important that you always comply with the following safety precautions:

- Do NOT remove the protective grille
- Do NOT open or disassemble the tweeter
- In case of fire, REMOVE the speaker from the heated area. In case the beryllium product has been in a fire zone, follow the safety recommendations in the material safety data sheet.

The Beryllium diaphragm is surface treated, which prevents direct contact with beryllium as long as it is not broken, and the diaphragm is placed behind the protective grille in order to prevent diaphragm from being touched and potentially break.

Recycling programme: Beryllium tweeter producer – Scan-Speak has arranged a beryllium material recycling programme. All units for repair, service, scrap etc. must be returned to Scan-Speak (check the shipping address with Estelon factory first) and they will take care of recycling the beryllium dome. Put the tweeter into a plastic bag inside a cardboard box. If the beryllium tweeter is broken, use double plastic bags, collect loose particles with adhesive tape and put it in the plastic bag. For handling beryllium, always follow the safety recommendations in the material safety data sheet. Please label the box as well as shipping papers with "For Recycling" for proper and safe handling at their facilities.

Please familiarize yourself with the material safety data sheet for information and safety precautions on beryllium:

**<http://www.scan-speak.dk/docs/M10.pdf>**

## **ESTELON / ALFRED & PARTNERS - Technical Services**

### **Alfred & Partners OÜ Five Year Limited Warranty Terms and Conditions**

- 1. Limited Warranty** – All ESTELON products purchased from authorized ESTELON dealers are covered by a limited 5-year non-transferable warranty granted by Alfred & Partners OÜ. This warranty includes all parts and labour charges as well as return-shipping charges (product owner is responsible for all shipping and insurance charges one-way to the ESTELON repair facility).

Upon receipt of an online registration form, Alfred & Partners OÜ warrants the purchased product to be free from manufacturing, materials, and workmanship defects for **five years** from the date of original purchase, subject to the following conditions. **Failure to register the ESTELON product within 30 days from original purchase will result in a warranty period of 90 days from the date of purchase.**

Customers should consult with their original ESTELON dealer or distributor for possible alternate repair instructions prior to contacting the ESTELON factory. Other ESTELON dealers or distributors may refuse from assisting the Customer under the limited warranty BUT under any and all circumstances customers are welcome to contact our sales department, listed on our web site [www.estelon.com](http://www.estelon.com), for service assistance.

This limited warranty is valid only in the country where the product was originally purchased. If the repair request that is covered under this warranty comes from another country then the Manufacturer may request the Customer to compensate to the Manufacturer additional costs arising from providing this limited warranty in another country than the country of original purchase.

This limited warranty shall not affect the statutory rights of the Customer.

- 2. Limited to Original Purchaser** – This warranty is for the sole benefit of the original purchaser of the covered product, and may

not be transferred to a subsequent purchaser of the product.

- 3. Conditions and Limitations** – This warranty is subject to certain conditions and limitations, as follows. This warranty is void and inapplicable if the product has not been used in accordance with the instructions found elsewhere in the owner’s manual, or if it has been misused or abused, damaged by accident or neglect, or in transport once in possession of the purchaser. The warranty is also deemed void if the product has been repaired, modified, or tampered with by anyone other than Alfred & Partners OÜ or its specifically authorized agents. Please Note – if the fasteners to the cover of the crossover area, those covered with multi coloured specialty epoxy seal, have been tampered with / the epoxy removed – the warranty will considered to be void.

This warranty does not cover defects due to accidents or similar causes arising after the risk for the product has passed to Customer, or normal deterioration, wear and tear.

- 4. Remedy** – If this product contains a materials, manufacturing, or workmanship defect that cannot be repaired at the dealership where the product was purchased, it must be packed in original packaging and returned to Alfred & Partners OÜ via insured freight, at the owner’s expense. If replacement packaging materials are required, they may be purchased from the factory at a charge. **Returned products must be accompanied by a written description of the defect, and a return authorization number (available from the factory via phone or email).**

Upon receipt of defective product, ESTELON agrees to repair the product without charge for parts or labour. The product will then be returned via prepaid, insured freight, with carrier at the sole determination of ESTELON. This constitutes the purchasers sole remedy.

- 5. Design Changes** – ESTELON reserves the right to modify its products or change specifications at any time without obligation or liability to previous purchasers.

6. **Miscellaneous** - Any implied warranties relating to the above product shall be limited to the duration of this warranty. This warranty does not extend to any incidental or consequential costs or damages to the purchaser. This warranty gives you specific legal rights. You may also have other rights which vary from country to country.

### **Instructions for Obtaining Repair Service**

1. Complete the Return Authorization Request Form – available online at [estelon.com/support](http://estelon.com/support).
2. Upon clicking the 'Submit' button on the Return Authorization Form, the ESTELON factory will review it for completeness and return an e-mail to you with an RA number when required (please allow 2-5 days for a return e-mail).
3. Crate and / or package the product **in its ORIGINAL FLIGHT CASE CONTAINERS ONLY**, according to the instructions included in the return e-mail, and ship the product to the shipping address included in the e-mail. The owner is responsible for paying the shipping and insurance charges (Alfred & Partners OÜ will cover return shipping and insurance charges on warranty repairs).
4. **In the case of non-warranty repairs**, Alfred & Partners OÜ will physically inspect the product and contact the customer for repair approval. Upon approval and completion of repair, the product owner will be informed of the final charges (including return shipping). Payment may be made by bank / wire transfer prior to final shipment). Payments not received within 30 days of initial contact may incur storage fees.

We strongly recommend that all product repairs should be conducted through the ESTELON factory or an authorized ESTELON repair facility. ESTELON products are designed and manufactured to the highest tolerances with numerous hand-picked components; for this reason, we HIGHLY RECOMMEND that components not be serviced by non-authorized repair facilities. Alfred & Partners OÜ values its loyal customers and will make every attempt to return repaired products to their original factory specifications. Customers should consult with their original ESTELON dealer or distributor for possible alternate repair instructions prior to contacting the ESTELON factory. BUT under any and all circumstances customers are welcome to contact our sales department, as listed on our web site [www.estelon.com](http://www.estelon.com), for service assistance. All non warranty repairs are warranted for one year from the date of return shipment.

*Have we answered all your questions?*

*If not, please send us an email with your questions to [sales@estelon.com](mailto:sales@estelon.com)*

**[www.estelon.com](http://www.estelon.com)**

Estelon Model YB is handmade in Estonia

ESTELON is a trademark of Alfred & Partners OÜ

Alfred & Partners OÜ  
Tanuma 126  
13521 Tallinn  
Estonia