

estelon

from Alfred & Partners



*Designed
by Alfred Vassilkov*

Model X Centro
Diamond Mk II

Serial Number _____

Your ESTELON loudspeakers have passed our quality control:

– Technical test passed.

Engineer, Estelon

– Listening test passed.

Alfred Vassilkov
Head of Research and Development, Estelon

Table of Contents

| | |
|---|----|
| 1. INTRODUCTION | 4 |
| 1.1. ALFRED & PARTNERS OÜ | 4 |
| 1.2. ESTELON X CENTRO DIAMOND Mk II | 6 |
| 1.2.1. Cabinet Design..... | 7 |
| 1.2.2. Transducers..... | 8 |
| 1.2.3. Crossovers | 9 |
| 1.2.4. Finish..... | 10 |
| 2. SPECIFICATIONS | 11 |
| 3. UNPACKING INSTRUCTIONS..... | 12 |
| 4. SET-UP | 14 |
| 4.1. POSITIONING | 14 |
| 4.2. INSTALLING THE BASES..... | 14 |
| 4.3. WIRING | 17 |
| 4.4. BREAK-IN PERIOD..... | 17 |
| 4.5. SET-UP RECOMMENDATIONS BY ALFRED VASSILKOV..... | 18 |
| 5. TAKING CARE OF YOUR ESTELON SPEAKERS..... | 18 |
| 6. ESTELON / ALFRED & PARTNERS OÜ – TECHNICAL SERVICES..... | 20 |

1. INTRODUCTION

1.1. Alfred & Partners OÜ

Alfred & Partners, the Tallinn-based design studio, think-tank, and owner of Estelon, is not simply a business but a passionate dedication to a single, heartfelt idea: the development and manufacturing of instruments capable of unveiling the rich, emotional tapestry of music in a personally involving and captivating way.

For more than 35 years Electro-acoustics Engineer and company founder, Alfred Vassilkov, has been relentlessly designing loudspeakers. His designs have been awarded numerous patents while also achieving much success in Europe. In 2010 a decision was made: to establish his own brand based on his extensive experience, knowledge, and relentless passion.



Alfred Vassilkov, the Designer and Founder of Estelon

Such dedication carries the implicit responsibility of a wholly uncompromising approach to audio design. Pride of craftsmanship shares equal footing with sonic innovation. Alfred Vassilkov's visionary achievements along with his tireless drive and quest for musical truth created an innovative brand of loudspeakers whose products offer unrivalled musicality and incomparable beauty: Estelon. More importantly, Estelon offers a distinctive key that assists listeners in unlocking the vast structure of emotion through music.

For the Estelon brand, the visionary development started in 2006 when Alfred started analyzing materials and technologies for producing cabinets with streamlined shapes that could not only reproduce the best sound but also assimilate into home interiors with an elegant, sculptured look. Years of research and development led him to a proprietary, crushed marble-based composite. The material, having excellent stiffness and anti-resonant attributes, as well as various technical advantages, allows the creation of molded cabinets with a purposeful design that enhances the sound quality of the entire audio system. Estelon's unique E-lon® shape creates the ideal conditions for sound reproduction. Its curved, smooth form eliminates corner reflections. A sculpted narrowing of the area where high frequency emanates helps achieve 0 degrees phase at the listening position, while the cabinet's larger radiuses create controlled directivity of the propagating soundwaves. The cabinet then becomes wider and deeper at its base for both stability and to allow effective low-frequency reproduction.

Every loudspeaker produced must pass Alfred & Partners' extreme level of quality control. Each pair of loudspeakers is completely hand-built, painted, assembled, tuned, tested, and then listened to individually. All Estelon products are meticulously handmade in Estonia, to the company's exacting standards.

1.2. Estelon X Centro Diamond Mk II

Estelon X Centro Diamond Mk II: Outstanding performance combining the best in sound and design which is the hallmark of Estelon products.

Paramount among the physical design elements continues to be the use of the E-Ion© shape cabinet form. This form has been developed and perfected over a five-year period. Its design and construction allow it to easily couple with non-acoustically treated listening areas (i.e. normal living spaces). Our respect for the legacy Model XA and its design continues and remains a constant source of inspiration. Premium quality components in separate chambers, state-of-the-art carbon-fiber resonant control, and applied isolation technology along with top-quality dampening materials, are all contributing factors to an exhilarating audio experience.

Many years have passed since the genesis of the Estelon, and much has been learned while embodying all achievements. The roots and choices have evolved into the Estelon sound. With the X Centro Diamond Mk II, the most beloved element of Estelon products has been reaffirmed again: simplicity. Featuring “minimalistic” second-order crossovers and the refined combination of the selected drivers and the acoustical attributes of the enclosure, has allowed Estelon to achieve their signature sound along with enhanced performance qualities.

The integrated stand has a well-designed base, milled from thick billet aluminium. The base is then attached to a sleek, aluminium tube that secures the speaker. This construction gives the speaker the necessary stability to eliminate vibrations and improve fidelity.

The X Centro Diamond Mk II is intended to be used as a centre channel to provide an unparalleled sound performance with an unprecedented level of musical accuracy in multichannel music systems and home theatres. It is far more than speaker drivers in a

cabinet. It is a genuine musical instrument in its own right, and when carefully integrated into a system and listening space, it is capable of connecting the listener to the music in a most profound and transcending way. Everything is expressed naturally, balanced, and emotionally engaging. The X Centro Diamond Mk II possesses an eminently musical temperament that is immediately evident upon your first audition and every subsequent listening experience.

The X Centro Diamond Mk II is capable of reproducing the finest nuances of music.

1.2.1. Cabinet Design

Chief among the physical design elements of the X Centro Diamond Mk II is the use of the E-Ion[®] cabinet form that has been developed and honed over many years of research and testing in order to find the right material that would allow the highest quality of cabinet and construction for the loudspeaker's acoustically engineered shape. The cabinet is extremely rigid, highly dense, resonant-free, and with exceptional internal dampening and acoustical control. This is the result of time-honoured construction techniques, a special casting process, the use of a proprietary marble-based composite along with the extensive use of sub-structural stiffening spars that break up resonance nodes and create an internal acoustic chamber of non-parallel sidewalls that is all but immune to unwanted standing waves that can cause a coloured sound. This is why the Estelon speakers reproduce a very natural and balanced sound.

Unusual in its defined form, the result of this cabinet construction allows it to be easily placed even in an acoustically untreated room, allowing the audio signal to roll effortlessly into the listening space.

1.2.2. Transducers

The German-made Accuton drivers employed are the highest expression of transducer design. The two 173 mm (7") mid-woofers have ceramic membranes, providing ultra-fast impulse response with significantly reduced total harmonic distortion (THD) and intermodulation distortion (IMD), as well as increased frequency bandwidth and linearity.

The design is highly sophisticated with particular attention paid to the 32mm titanium voice coil former and the surrounding air gap which provide maximum freedom from dynamic compression in conjunction to the use of the ultra-stiff ceramic dome, which is valued for its midrange neutrality. All moving elements of the drivers are ventilated for a resonance-free response. This unique technology allows the X Centro Diamond Mk II to produce bass and dynamics that belie the size of the loudspeaker enclosure.

The 25 mm (1") chemical vapor-deposited diamond membrane tweeter from Accuton can reproduce sounds up to the highest frequencies (up to 60 kHz), with no distortions in the human hearing range. Diamond is the hardest known material, with the highest speed of sound in any known material. This results in a perfect step response, while the first breakup modes occur way out of the human hearing range. The imaging precision, the instrument spatiality, the contours in 3D space, and the microdetail clarity produced by this tweeter is unmatched.

The sonic character of the Estelon loudspeakers that feature diamond tweeters is not what you would expect: an overly "brilliant" or "hard-as-diamond" sound, which in most cases is caused by a high amount of harmonic distortion. In our loudspeakers, through the properly designed crossover, the diamond tweeters simply disappear, and only the music remains. It is like being present at a live concert

where one can hear the instruments but not the speakers reproducing the sound. The Estelon Diamond loudspeakers offer a new way of relaxed listening, and you get to sense all the details that you have never heard before on your old records and digital music. You will be immersed in acoustical spaces with a “live” 3D presence that was never there before.

Each drive unit is “broken-in” by running an audio signal through them for several hours before selecting matching drivers for each pair of speakers. When the drivers are in matching pairs, another “break-in” with an audio signal is conducted. Finally, drivers are fitted into the finished cabinet for individual tuning.

1.2.3. Crossovers

The Estelon X Centro Diamond Mk II has a finely tuned crossover. It is second-order, allowing it to be incredibly fast and with perfect phase transition. The crossover point of the tweeter and mid-woofer is at 1.9kHz.

Countless hours of R&D and real-world listening test have been conducted of each crossover design and its related parts, right down to the physical placement of each part and its positioning within the cabinet. The crossover components have been chosen from among the absolute best available, and the synergy of the end result has been a significant deciding factor.

In order to achieve the highest degree of micro-detail fidelity, the filter components are connected directly, via point-to-point techniques, all hand-soldered with high-quality solder, and with the shortest possible cable runs between drivers, crossover and binding posts. All internal cabling is from the renowned cable manufacturer Kubala-Sosna.

Each crossover construction process involves careful attention from our engineers and designers, where every process is carefully thought out and each component tested to make sure that the final result is according to reference. After passing technical measurement tests, the finished speaker is put through extensive critical listening tests.

1.2.4. Finish

Just as in the making of a great musical instrument, the finish has also an influence on the outcome. Because of the highly sophisticated cabinet shape, all the processes in the finishing stage are hand-made with extreme care by highly experienced specialists using the best technology and procedures. After casting the proprietary marble-based composite, it is allowed to age. Then the preparation of the surface of the cabinet commences by hand sanding and by sealing layer upon layer through an elaborate and time-consuming procedure. Finally, the multiple coats of the lacquer finish are applied along with the final polishing to a mirror-like finish. The Estelon X Centro Diamond Mk II is offered in a choice of liquid gloss, matte, or the optional premium finishes.

2. SPECIFICATIONS

| | |
|--|--|
| TYPE: | 2-way passive speaker, bass reflex |
| DRIVERS: | |
| 2 x Mid-woofer: | 173 mm (7") Accuton, ceramic membrane |
| Tweeter: | 25 mm (1") Accuton, diamond inverted dome |
| INTERNAL WIRING: | Kubala-Sosna |
| FREQUENCY RESPONSE: | 45-60 000 Hz |
| POWER RATING: | 150 Watts |
| NOMINAL IMPEDANCE: | 8 Ω (min 4.9 Ω at 3.4 kHz) |
| SENSITIVITY: | 91 dB / 2.83 V |
| MINIMAL AMPLIFIER POWER: | 20 Watts |
| DIMENSIONS (with integrated stand): | Height: 365 mm (14.4") Width: 724 mm (28.5") Depth: 367 mm (14.4") |
| NET WEIGHT: | 48 kg (108 lbs.) |
| SHIPPING WEIGHT: | 78 kg (170 lbs.) |

3. UNPACKING INSTRUCTIONS

The packaging is precisely thought-through so despite the weight of 48 kg (108 lbs.) of the speaker, it can be quickly and safely transported to their final position in the room.

The speaker is shipped in a transport case (industrial grade custom flight-case). We recommend keep the case for possible future transportation. Due to the substantial weight and slippery surface of the loudspeaker, we suggest that **two able-bodied individuals assist in the unpacking and positioning process.**

Contents of the flight case:

- 1 loudspeakers
- 1 Accessories box:
 - 1 set of spikes (4 pieces)
 - 1 sets of locking ring (4 pieces)
 - 1 sets of floor plates (4 pieces)
 - 1 user's manual
 - 2 pairs of gloves
 - 1 polishing cloth

For unpacking, please follow the instructions described below and as shown in the drawings:

1. Unlock/open all four locks of the flight case cover while the speaker/flight case is in a horizontal position (drawing 1).
2. Carefully lift and remove the cover from the flight case (drawing 2).

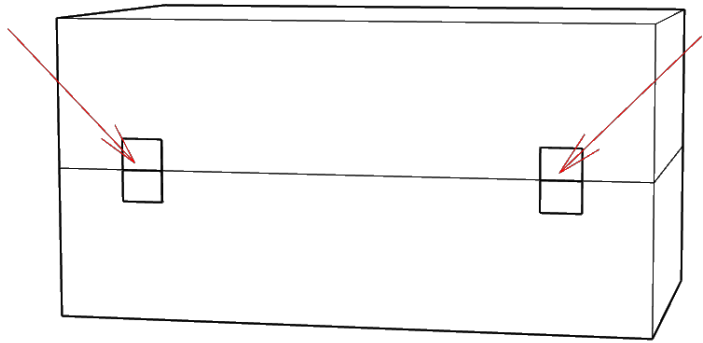

1

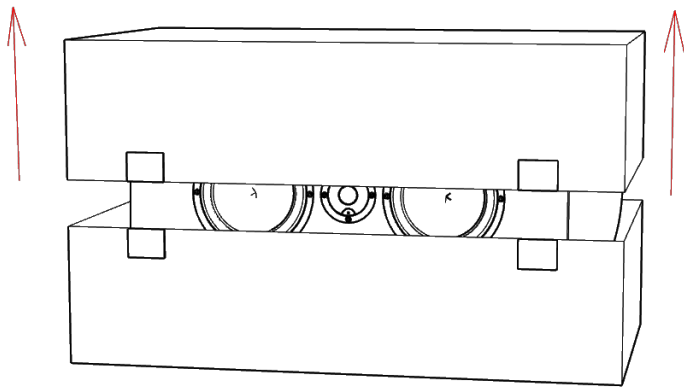

2

3. Lift the speaker and remove it from the flight case and place it in the desired position.
4. Then carefully remove the cloth bag.

4. SET-UP

4.1. Positioning

When positioning the speaker, it is advised to allow enough "free" space around the speaker to minimize sound reflections from walls, furniture, decorative elements etc. This will contribute to achieving correct tonality, realistic imaging, focus, and dynamics.

Please contact your dealer for consultation on how to improve your room acoustics.

4.2. Installing the bases

The Estelon X Centro Diamond Mk II speaker is shipped with the isolation feet preinstalled on its base.

You will need to assemble the spikes **with the locking rings** as shown in drawing 3.

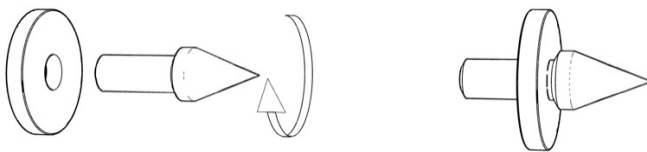

3

Once you have assembled the bases and the final position of the speaker has been located, it is time to insert the spikes into the isolation feet. Please **insert the spikes on one side of the speaker at a time**.

One person should carefully tilt the speaker against himself/herself and hold it in this position (drawing 4), while the other person screws the spikes into the two isolation feet as shown in drawing 5. Please **make sure the edge of the base of the speaker's stand does not touch the surface of your furniture** during this process.

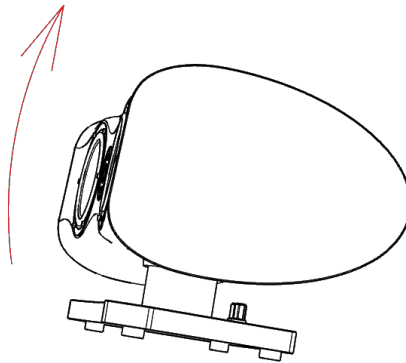

4

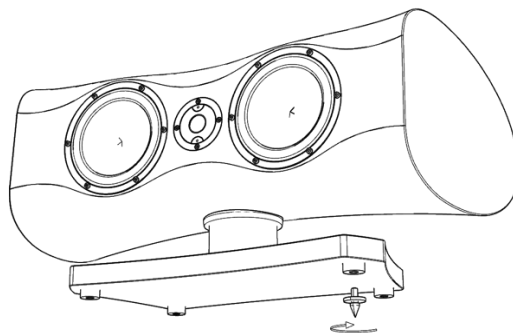

5

Lastly, please place the **floor plates** onto the furniture before lowering the speaker on the side that the spikes were inserted (drawing 6). The floor plates are for use on hard surfaces in avoid any damage from the spikes.

Repeat the process for inserting the rest of the bases on the loudspeaker.

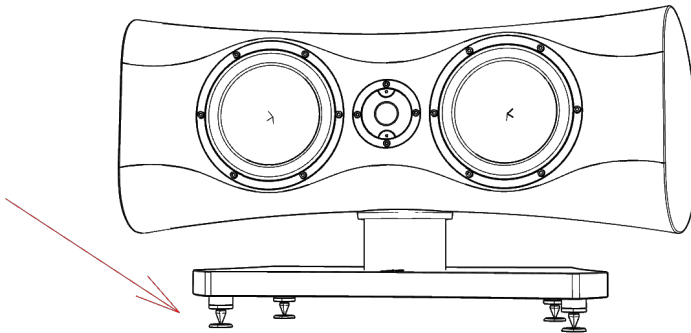

6

In case of an uneven surface please follow the steps described below, and as shown in the drawings, in order to achieve good stability and a properly levelled loudspeaker. Please locate the spikes that do not touch the floor/floor plates and then:

- i) Firmly hold the isolation foot to stay in place and unscrew the locking ring.
- ii) Keep holding the isolation foot and unscrew the spike till it reaches the right length and touches the floor/floor plate.
- iii) While firmly holding the spike in the adjusted height position, tighten the locking ring until the spike is firmly and securely seated.

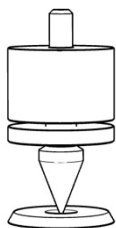

i)

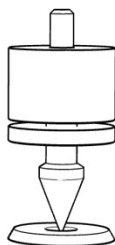

ii)

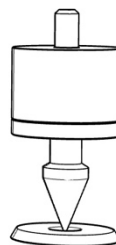

iii)

Proper use of the isolation feet and spikes/floor plates will achieve accurate audio reproduction with fast and deep bass, focused imaging, and avoiding colouration in the midrange frequencies.

4.3. Wiring

When connecting the speaker to the amplifier please make sure that the amplifier is in the off position. Connect the speaker cable to the pole terminal on the back of the speaker: speaker terminal „+“ with the amplifier terminal „+“ and „-“ with „-“. For signal flow, please follow the direction marked on the cable or in the cable manufacturer's instruction. Typically, the signal flow is in the same direction as the labelling/writing on the cable.

4.4. Break-in period

Although all Estelon speakers have an initial “break-in” at the factory, due to shipping conditions and pressure/temperature changes that may have incurred, the speakers will need to go through an additional “break-in” process before their final set-up. All the

mechanical and electrical connections will stabilize naturally after playing a continuous music signal for approx. 24 hours – e.g. use a digital source on repeat mode. After the initial “break-in” period, you can start setting-up the sound according to Alfred Vassilkov’s recommendations. Please note that the speakers should reach their optimum level of performance after about 300-400 hours of use.

4.5. Set-up recommendations by Alfred Vassilkov

The set-up of the sound consists of the balance between different parameters such as tonality, bass accuracy, focus, stage imaging, depth, etc. The time required for this process depends on the listener’s experience and skills. Proper set-up will maximize the speaker’s performance. We suggest that you test and listen to various musical pieces from different genres to avoid specific sonic accents.

Please keep in mind when changing the position of your speaker that close proximity to the front wall will reinforce, enhance, the bass performance.

Before critical listening, please allow 60-90 minutes of playback for system-stabilization. When listening at an excessive volume you risk damaging the drivers.

5. TAKING CARE OF YOUR ESTELON SPEAKERS

The multi-coated finish applied to Estelon speakers is considered the most advanced automotive finish available. It is extremely strong and durable. In order to maintain the speakers’ immaculate appearance, special cleaning cloths are provided with your Estelon loudspeakers. Please note that only dry cleaning is

allowed. Do not wash the speakers. In case of a smudge/spot, please use a damp, soft, lint-free cloth to clean the smudges before the final finishing with the special cloths that accompany the speakers. For the Liquid Gloss finish, please use only the polishing cloth included in the flight case. Please do not apply polishing to the speaker drivers. The use of other materials can damage, scratch, or destroy the finish.

Additional information regarding the polishing cloths and other products:

For all finishes:

- Use with the provided microfiber cloth: Würth Active Glass Cleaner (Item # 089025) Silicone-free
- 3M Perfect-It III High Performance Polishing Cloth (Item # 50486) or any 3M Microfiber cloths

For Liquid Gloss finish only:

- Window Cleaner (with alcohol)
- Polish cloth impregnated with Krytox® (DO NOT USE FOR MATTE FINISH)

No additional wax or polish is required.

For additional information and guidance regarding cleaning/polishing materials, please contact your dealer or distributor.

6. ESTELON / ALFRED & PARTNERS OÜ – Technical Services

Alfred & Partners OÜ Five Year Limited Warranty

Terms and Conditions

1. Limited Warranty – All ESTELON products purchased from authorized ESTELON dealers are covered by a limited 5-year non-transferrable warranty granted by Alfred & Partners OÜ. This warranty includes all parts and labour charges as well as return shipping charges (product owner is responsible for all shipping and insurance charges one-way to the ESTELON repair facility or ESTELON factory approved repair facility).

Alfred & Partners OÜ warrants the purchased product to be free from manufacturing, materials, and workmanship defects for **five years** from the date of original purchase, subject to the following conditions.

Customers should consult with their original ESTELON dealer or distributor for possible alternate repair instructions prior to contacting the ESTELON factory. Other ESTELON dealers or distributors may refuse from assisting the Customer under the limited warranty. BUT under any and all circumstances customers are welcome to contact our sales department, listed on our website www.estelon.com, for service assistance.

This limited warranty is valid only in the country where the product was originally purchased. If the repair request that is covered under this warranty comes from another country, then Alfred & Partners OÜ may request the Customer to compensate Alfred & Partners OÜ additional costs arising from providing this limited warranty in another country than the country of original purchase.

This limited warranty shall not affect the statutory rights of the Customer.

2. Limited to Original Purchaser – This warranty is for the sole benefit of the original purchaser of the covered product and may not be transferred to a subsequent purchaser of the product.

3. Conditions and Limitations – This warranty is subject to certain conditions and limitations, as follows. This warranty is void and inapplicable if the product has not been used in accordance with the instructions found elsewhere in the owner’s manual, or if it has been misused or abused, damaged by accident or neglect, or in transport once in possession of the purchaser. The warranty is also deemed void if the product has been repaired, modified, or tampered with by anyone other than Alfred & Partners OÜ or its specifically authorized agents. Please Note – if the fasteners to the cover of the crossover area, those covered with multi-coloured specialty epoxy seal, have been tampered with / the epoxy removed – the warranty will be considered to be void.

This warranty does not cover defects due to accidents or similar causes arising after the risk for the product has passed to the Customer, or normal deterioration, wear and tear.

4. Remedy – If this product contains a material, manufacturing, or workmanship defect that cannot be repaired at the dealership where the product was purchased, it must be packed in original packaging and returned to Alfred & Partners OÜ via insured freight, at the owner’s expense. If replacement packaging materials are required, they may be purchased from the factory at a charge. **Returned products must be accompanied by a written description of the defect,**

and a return authorization number (available from the factory via phone or email).

Upon receipt of a defective product, Alfred & Partners OÜ agrees to repair the product without charge for parts or labour. The product will then be returned via prepaid, insured freight, with the carrier at the sole determination of Alfred & Partners OÜ. This constitutes the purchaser's sole remedy.

Alfred & Partners OÜ undertakes during the warranty period to the exclusion of any other remedy to repair or replace the part of the product, which the examination by Alfred & Partners OÜ shows to have been defective. The warranty period for repaired or replaced parts shall not exceed the original warranty period and shall terminate along with the original warranty. The term of the original warranty shall not be extended by the duration of any warranty repairs.

5. Design Changes – ESTELON reserves the right to modify its products or change specifications at any time without obligation or liability to previous purchasers.

6. Miscellaneous – This warranty does not extend to any incidental or consequential costs or damages to the purchaser. This warranty gives you specific legal rights. You may also have other rights which vary from country to country.

Instructions for Obtaining Repair Service

1. Complete the Return Authorization Request Form – available online at estelon.com/support.
2. Upon clicking the 'Submit' button on the Return Authorization Form, the ESTELON factory will review it for

completeness and return an e-mail to you with an RA number when required (please allow 2-5 days for a return e-mail).

3. Crate and/or package the product **in its ORIGINAL FLIGHT CASE CONTAINERS ONLY**, according to the instructions included in the return e-mail, and ship the product to the shipping address included in the e-mail. The owner is responsible for paying the shipping and insurance charges (Alfred & Partners OÜ will cover return shipping and insurance charges on warranty repairs).

4. **In the case of non-warranty repairs**, Alfred & Partners OÜ will physically inspect the product and contact the customer for repair approval. Upon approval and completion of the repair, the product owner will be informed of the final charges (including return shipping). Payment may be made by bank/wire transfer prior to the final shipment). Payments not received within 30 days of initial contact may incur storage fees.

We strongly recommend that all product repairs should be conducted through the ESTELON factory or an authorized ESTELON repair facility. ESTELON products are designed and manufactured to the highest tolerances with numerous hand-picked components; for this reason, we HIGHLY RECOMMEND that components not be serviced by non-authorized repair facilities. Alfred & Partners OÜ values its loyal customers and will make every attempt to return repaired products to their original factory specifications. Customers should consult with their original ESTELON dealer or distributor for possible alternate repair instructions prior to contacting the ESTELON factory. BUT under any and all circumstances customers are welcome to contact our sales department, as listed on our website www.estelon.com, for service assistance. All non-warranty repairs are warranted for one year from the date of the return shipment.



*Have we answered all your questions?
If not, please send us an email with your questions at
sales@estelon.com*

www.estelon.com

ESTELON is a trademark of Alfred & Partners OÜ

Alfred & Partners OÜ

Kukermiidi 6

Tallinn, 11216

Estonia

Notes